

PerfectREC System/Optimum Compaction & Recycling Machine of Grinding Steel Sludge

H. UENO M. SEDOH M. MATSUDA

Grinding steel sludge presents is difficulty because it is fine-grained, includes water and oil, and oxidizes easily. Therefore it is treated as industrial waste and placed in landfills despite the fact that it contains iron with a high degree of purity. The JTEKT PerfectREC System uses revolutionary press-forming and hardening technology to solidify the grinding steel sludge into a form having sufficient strength to withstand truck transport and rough handling by magnet-lifting in steelmaking factories. This PerfectREC System not only contributes to global environmental protection but also creates value as the solidified Value Packs can be sold to steelmaking factories as raw material.

Key Words: grinding steel sludge, recycling, compaction, zero emission, global environmental protection

1. Introduction

In addition to OECD countries, Brazil, Russia, India and China (known as BRIC countries) have been promoting economic development policy at a fierce pace. Continuation of such production activities would soon deplete various earth resources and reach the environmental limit in which human beings can live.

Problems such as over consumption of limited resources, rising crude oil prices and abnormal climate activity, probably caused by global pollution, including natural disasters have stimulated active global discussion. Thus, many companies have accelerated implementation of zero emission and recycle systems. The authors accept that keeping the global environment healthy and safe for everyone's children is more important than the pursuit of economic efficiency.

A large quantity of grinding steel sludge generated by metalworking factories contains a lot of water and oil and is easily oxidized due to the material's small particle size. Thus, in spite of the high iron purity of grinding steel sludge, it has been classified as industrial waste due to the difficulty in treatment and has been disposed by landfill as industrial waste.

This report describes JTEKT's PerfectREC System that has enabled the recycling of grinding steel sludge which could not be recycled before so far and one which has been one of environmental pollution sources due to disposal by landfill and also describes the Fully Automatic Compaction Machine USS-015 as the basis for the PerfectREC System.

2. PerfectREC System: Recycling Technology for Grinding Steel Sludge

In recent years, scrap iron called as the market scrap has been discharged by various production factories and more than 30 million tons of scrap iron has been collected and recycled annually. The market size exceeds one trillion yen. This scrap iron has been returned to steel manufacturers and recycled as a valuable resource. With the authorization by Ministry of Economy, Trade and Industry, scrap iron was listed in the Central Japan Commodity Exchange in October 2005 first in the world as a commodity for the commodity futures market, so that scrap iron has been more remarkable in economic interest than before. The listed scrap iron includes machining scrap called as chips or turnings. However, since grinding steel sludge has been recognized as matter impossible to be recycled, it is not included on the list. Recently, some steel manufacturers have experimented with inserting compressed grinding steel into the furnace and tried to use it as iron feedstock and buffer material. However, due to insufficient strength, the compressed grinding steel was scattered or discharged as powder dust, resulting in quite a low iron yield ratio. Thus, it cannot be said that grinding steel sludge has been recycled.

Figure 1 shows the outline of the grinding steel sludge recycling system "PerfectREC System."

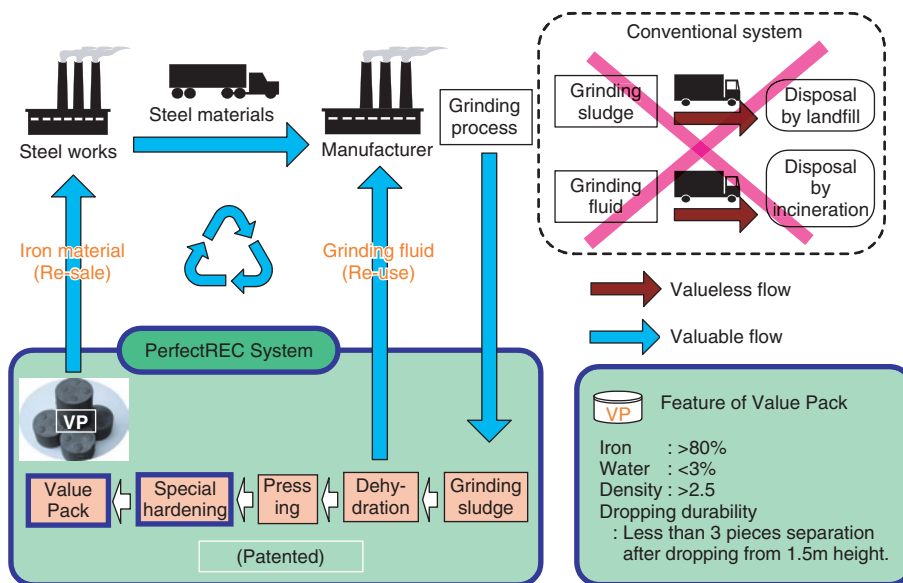

Fig. 1 PerfectREC System

The PerfectREC system is installed in the immediate vicinity of the grinding process of a plant, as an associated process. The PerfectREC System performs not only compression molding of grinding steel sludge without lowering metal purity but also solidification of grinding steel sludge with an original hardening technique. The solidified matter obtained from grinding steel sludge is called the Value Pack; it has enough strength for truck transportation and for input into an electric furnace at a steel manufacturer and also has yields equal to that of other machining scrap. Therefore, the Value Pack can be sold to steel manufacturers as a valuable resource and can be directly used as iron feedstock for the manufacturing process. JTEKT has achieved the perfect recycling system, which can restore waste metal material to its original quality.

The PerfectREC System has eliminated disposal by landfill of grinding steel sludge that contributes to soil contamination and has eliminated the cost of industrial waste disposal by landfill. This system has also converted industrial waste to valuable material that can be sold to steel manufacturers as iron feedstock. Thus, this system contributes significantly to global environmental protection and creates economic value out of conventional industrial waste. The sale of Value Pack to steel manufacturers began in January 2002. This system is now used in five domestic (Japanese) factories where bearing or automobile-related products are manufactured.

The PerfectREC System also allows the recycling of grinding fluid by collecting grinding fluid during the molding process. It was difficult to separate grinding fluid from grinding steel sludge previously and thus grinding fluid was burnt.

Figure 2 summarizes the features of the PerfectREC

System. Grinding steel sludge has a composition of high quality steel powders, abrasive grains and grinding fluid that gives it a clay-like texture, which has contributed to the stereotype that grinding steel sludge cannot be recycled. However, this system enables grinding steel sludge to handle solid material (Value Pack) through compression molding. The major advantages of the Value Pack are easy transportation to the steel manufacturer and the complete abolition of the disposal of industrial waste. From the economic point of view, there is the advantage that the Value Pack can be sold as a valuable resource at a profit, but it offers a significant economic merit for factories by eliminating the entirety of the costs of industrial waste disposal.

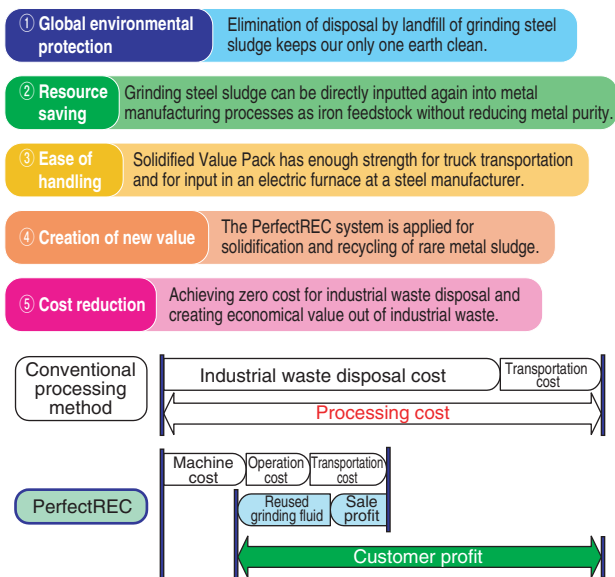

Fig. 2 Features of PerfectREC system

3. Introduction of New Solidification Machine: Fully Automatic Compaction Machine USS-015

In 2005, JTEKT has unitized a series of solidifying processes of grinding steel sludge including dehydration, molding, hardening and drying, and developed a fully automatic machine that can perform a series of processes from the input of sludge to the completion of Value Pack. This machine has been already used in JTEKT Nara and Toyohashi steering manufacturing plants in Japan. And now, JTEKT has been expanding its installation in foreign plants and has already installed this machine in plants in the U.S., Thailand and Britain.

Figure 3 shows the appearance of Fully Automatic Compaction Machine USS-015. **Figure 4** shows the machine currently used in Nara Plant. External hopper and elevator have been developed as ancillary components.



Fig. 3 Fully automatic compaction machine USS-015

3.1 Structure and Features of Machine

Figure 5 shows the internal structure of the machine and **Table 1** shows its features. This machine has a basic structure including a space-saving two-level design: the first level comprises the press process and the second level comprises the drying process. Furthermore, by placing the hardening fluid tank under the press machine instead of outside of the machine, workability, compactness, and energy saving improved. The design details of the sludge input section, metal press mold, metal mold fixture, transportation conveyer, immersion section, dryer and the safety device have been improved reflecting the opinion of current customers.

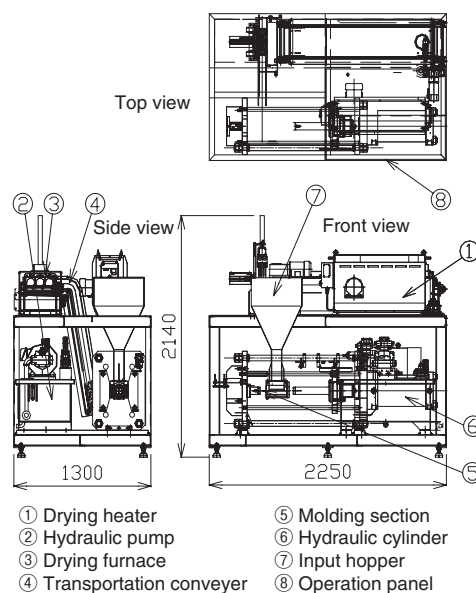

Fig. 5 Machine internal layout



(Left: a full view of machine, Right: Value Pack produced by the machine)

Fig. 4 Nara Plant's machine

Table 1 Machine features

Items	Contents	Features
Type	Integrated automatic machine	After inputting sludge, Value Pack is formed completely automatically.
Required installation area	3 m ²	Space-saving two-level design minimizes installation area.
Processing capacity	15 tons/month by one shift	Maximum monthly output is 20 to 30 tons.
Shape of Value Pack	φ65 × 50mm	Sufficient strength for transportation is secured.

3. 2 Molding of Grinding Steel Sludge

The dehydration process and the molding process are performed by compression of the grinding steel sludge within the same mold. As the dehydration performance largely depends on the combination of grinding steel sludge and grinding fluid, the metal mold structure is optimized for superior dehydration performance and compression speed is adjusted to an optimal value depending on its performance.

Figure 6 shows a magnified photograph of the grinding steel sludge that is generated from the grinding of the gear or rack (hardened steel) of an automobile steering component. Although grinding steel sludge can seem like fluffy powder or cotton to the naked eye, grinding steel sludge actually has a curled beard-like shape. Grinding steel sludge seems to be a material well solidified from such shape because it intertwine during compression molding. However, this shape results in having a spring property during the compression to cause deformation after the compression. This phenomenon is particularly evident in hardened grinding steel sludge but is also observed in unhardened grinding steel sludge. Thus, grinding steel sludge is typically deformed during transportation to the steel manufacturer or prior to input into the furnace. To prevent this, the adjustable range for the compressing force needs to be set wider and a high compression pressure of 1 to 2.5 ton per 1 cm² is applied to grinding steel sludge. The grinding steel sludge is pressed and deformed to a degree that spring back does not occur and it can be solidified. Sludge with larger average particle size is easier to compress.

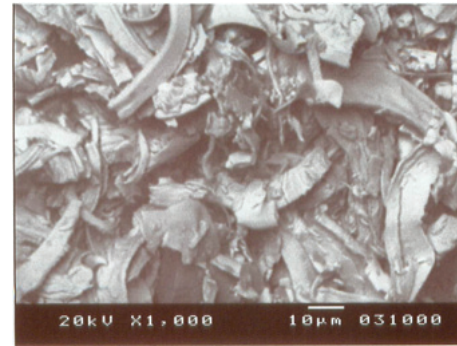

Fig. 6 Shape of general grinding steel sludge

Figure 7 shows a magnified photograph of fine grinding steel sludge of a high precision part. Different from general grinding steel sludge, fine grinding steel sludge normally has a particle diameter of around 1 µm. Therefore, it is necessary that the clearance of the compression mold is finished with an accuracy equal to that of a precision mold. The fine grinding process like the super-finishing process uses oil-base grinding fluid. This makes it difficult to separate sludge from grinding fluid and thus very low compression speed is required. For these reasons the solidification of fine grinding steel sludge by itself is not economical, while mixing the fine sludge with general sludge in an optimal ratio is effective.

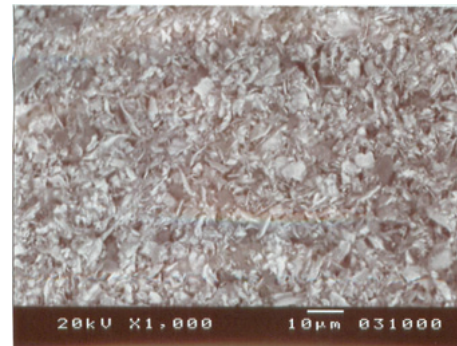

Fig. 7 Shape of fine steel grinding steel sludge

3. 3 Hardening Process of Grinding Steel Sludge

Iron-base grinding sludge produced just after grinding process is iron with a very active surface. When the iron powder is separated from the grinding fluid through compression and dehydration processes, is in contact with appropriate water and air and then are heated to a certain temperature, the iron powder with large specific surface area rapidly start to oxidize and change into iron oxide. How iron powder changes into iron oxide can be easily understood by imagining the activation level equal or higher than air turbulence after a rain gush in summer generated by turning scrap piled up outside of a back-street factory.

In order to simultaneously achieve both the chemical countermeasure for preventing this oxidization reaction and the measure for securing physical strength required for handling the grinding steel sludge as shown in **Fig. 8**, the Value Pack is immersed in the hardening fluid and the impregnation layer is formed from the surface of Value Pack to a depth of a few millimeters. The formed hardening coating layer prevents the oxidization reaction and secures the physical strength required for handling the Value Pack.

When inserting the Value Pack in the electric furnace

1. Strength is needed so that it does not become fine dust in the high temperature furnace.
2. Density is needed so that it can pass through the slag.
3. The water content should be low so that there is no explosion of water vapor.

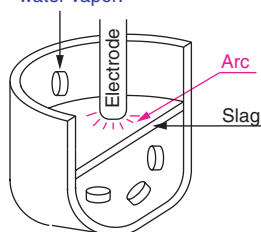

Value Pack being transported by lifting magnet

Fig. 8 Reason why strength is required for Value Pack

Materials that can be used as hardening fluids are colloidal silica, aluminum phosphate, and sodium silicate. These materials do not affect the steelmaking process when the coated Value Pack is heated in an electric furnace and are low cost. Actually, an aqueous solution of sodium silicate called liquid glass is used. The aqueous solution of sodium silicate is used in many applications such as a soil hardening agent (see JIS K1408 standard for sodium silicate).

Value Pack coated with liquid glass and optimally dried is never oxidized during collection and transportation by truck until it is put into an electric furnace of a steel manufacturer. Value Pack also satisfies the quality acceptance standards, shown in **Fig. 2**, by a steel manufacturer for iron feedstock.

3. 4 Drying of Grinding Steel Sludge

As grinding steel sludge is iron with an active surface, a natural drying process occurs for grinding steel sludge left in the waste yard of a plant. If the appropriate amount of water and temperature is added to such dry grinding steel sludge, it may cause self-ignition. For this reason, temperature control is very important in the hardening-fluid coating and drying process for the grinding steel sludge obtained through compression, dehydration and molding processes under high pressure. The temperature to dry the sludge is decided by positively determining the ignition temperature.

Figure 9 shows the results of the thermogravimetric analysis of grinding steel sludge.

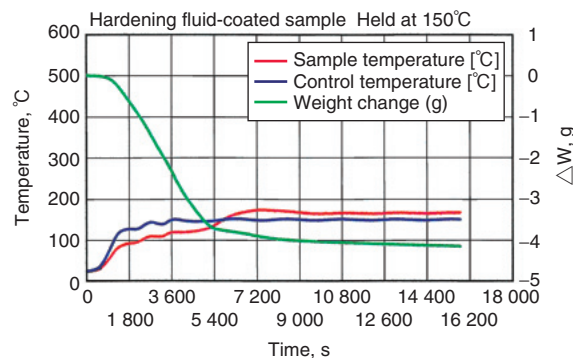

a) Test result of hardening fluid-coated sample at 150°C holding.

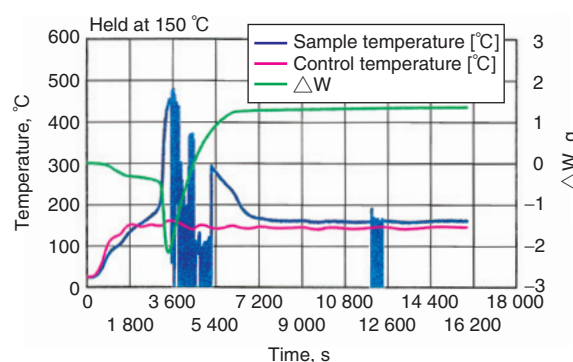

b) Test result of uncoated sample at 150°C holding.

Fig. 9 Thermogravimetric analysis of grinding steel sludge

Figure 9 a) and b) show the control temperature, the sample temperature and the weight change of a hardening fluid-coated sample and an uncoated sample that are kept at 150°C, respectively. The hardening fluid-coated sample in **Fig. 9** a) does not show an exothermic phenomenon after 4 hours. On the other hand, the uncoated sample in **Fig. 9** b) shows an exothermic phenomenon after 3 300 seconds (55 minutes): the sample temperature rapidly rises above 300°C. This result shows that the hardening fluid coating effectively prevents the oxidization reaction of the surface of the grinding steel sludge.

In a test to examine the drying conditions by thermogravimetric analysis, the accelerating effect of drying by air exchange cannot be confirmed completely because of the limited capacity of the analysis apparatus. Thus, this effect is examined and determined empirically from actual processing on the equipment. In the equipment, steam is expelled by air blasting to improve the drying efficiency. Thus, the drying temperature can be reduced to 110°C or less. This allows a larger safety margin with respect to the ignition point and saves electrical energy from a viewpoint of electric power consumption. One hour after inputting grinding steel sludge into the machine, the output of finished Value Pack is started. When the machine stop button is pushed,

the machine automatically stops after checking if Value Pack in the drying furnace is appropriately dried and discharged.

4. Introduction of PerfectREC System

In order to successfully introduce the PerfectREC system, it is important to thoroughly understand not only the flow of products in a manufacturing line, but also the flow of grinding steel sludge, which has been an undervalued useless waste before. Through the understanding of these flows, in addition to the five effects shown in Fig. 2, other significant improvements at manufacturing sites can be expected, such as ① an improvement in processing line efficiency, ② the integration and reduction of grinding fluid and ③ the reuse of grinding fluid.

Grinding fluid is a factor that largely influences hardening, particularly during the molding process. Most aqueous grinding fluid is easily solidified, but because emulsion type shows completely different behavior depending on manufacturer or the individual oil based fluid, thus requiring a preliminary hardening test. Furthermore, it is difficult to apply oil-based grinding fluid at economical compression speeds. Thus, it is considered that oil-based grinding fluid should be reduced by replacing it with aqueous grinding fluid.

By the introduction of this PerfectREC system, waste grinding steel sludge can be recycled as a valuable resource called Value Pack. By this, visible control of Value Pack from a logistics point of view is established and, as a result, attention is also paid to its appearance and quality.

A good example of the above is that when in a manufacturing line, the oil concentration of the grinding fluid became higher due to mixing in rust preventive oil from workpieces or hydraulic oil from machines, this was detected from the fact that it was difficult to solidify the grinding steel sludge in a good manner. Thus, the system also functions as a health monitor of the manufacturing line.

5. Conclusion

The current bubble in the metal market is caused by the increased demand for iron in China who is hosting the 2008 Beijing Olympics and the 2010 World Exposition in Shanghai. Thus, the price increase of scrap iron and copper is continuing. The importance of iron resource must be recognized again.

Even under such abnormal circumstances, almost all grinding steel sludge is still unused and wasted in Japan and the rest of world, even though grinding steel sludge is a valuable resource.

Production of 1 ton of pig iron requires 1.5 to 1.7 ton of iron ore, 0.8 to 1.0 ton of coal, 0.2 to 0.3 ton of limestone, 10 to 80 kWh of electric power, and 30 to 60 ton of water ("Hagane no Ohanashi," written by Hisashige Yamato). From an ecological viewpoint, the environmental pollution ore and emission of carbon dioxide caused by the mining of iron must be added. Thus, we must realize again how enormous amounts of resources are required to maintain our comfortable lifestyle.

JTEKT will make further efforts to widely apply the PerfectREC system as a standard system that allows grinding steel sludge to be recycled as Value Pack by input into the electric furnace and to be used repeatedly instead of being wasted.



H. UENO *



M. SEDOH **



M. MATSUDA ***

* Automotive Components Engineering Department, Bearing & Driveline Operations Headquarters
 ** Koyo Service Co., Ltd.
 *** Safety, Health & Environment Control Department, Production Engineering/Production/Logistics Division