

Development of Differential Gear Type Active-Front-Steering System

K. YAMANAKA A. ISHIHARA

JTEKT has developed a new active-front-steering system that greatly contributes to vehicle safety. This system includes a unit comprising two motors and a differential gear mechanism capable of controlling steering angle and compensating for reactive torque, making steering compensation without driver interference possible. By creating a unit with these functions, we have provided a system with a lightweight, low-cost design that does not require tuning work for each vehicle. Furthermore, it has been verified by on-vehicle evaluation that this system improves vehicle safety.

Key Words: active-front-steering, vehicle safety, steering angle control, steering torque compensation

1. Introduction

When steering the vehicle, the driver via the steering wheel needs to input not only the vehicle motion target values for turning but also make compensational operation for often changing road surface conditions or external disturbances (e.g. tire slippage on wet roads). The input of compensational steering is an important and difficult task of driver, and compensation mistakes have been the cause of many accidents. Because of this, an advanced steering compensation unit, which can reduce the load on the driver by automatically compensating the driver's steering to obtain vehicle motion on par with that obtainable by an expert driver, has been demanded.

We have verified the improvement of vehicle stability using a steer-by-wire (SBW) system (**Fig. 1**), in which case the steering wheel is not mechanically connected to the tires¹⁾⁻³⁾. In regard to electric power steering (EPS) systems (**Fig. 2**), which have become the mainstream in today's market, it is impossible to automatically compensate the driver's steering angle by electronic control because tire angle is determined directly based on the steering wheel angle. This system can only provide guidance torque for driver's compensation operation. However, the recently commercialized electronically controlled variable gear ratio (E-VGR[®]) system (**Fig. 3**) is capable of controlling steering angle. Controlling only steering angle makes it impossible to compensate for the reactive torque not intended by the driver, so this system is used mainly for as variable gear ratio steering to augment steering angle input by the driver during parking or low-speed driving. EPS makes it possible to compensate the

reactive torque not intended by the driver. To achieve both steering angle control and reactive torque compensation, this control system integrating the control of E-VGR[®] and EPS has already commercialized. However, EPS has high output because it must provide power assistance, and is not suitable for the precise control required for reactive torque compensation. In addition, when EPS is used for reactive torque compensation, it is necessary to conduct detailed tuning work for each vehicle to achieve the target performance. The man-hours required for tuning work is considered one of the factors preventing the expansion of vehicle stability control by steering. In order to solve such problems including cost and reliability and achieve the same level of vehicle stability performance as that of SBW, it has been necessary to create a completely new unit.



Fig. 1 Steer-by-wire (SBW) system



Fig. 2 Electric power steering (EPS) system



Fig. 3 Electronically controlled variable gear ratio (E-VGR®)

2. Outline of Unit

The newly developed unit integrates a steering angle control unit with a reactive torque compensation unit as shown in Fig. 4. By mounting the integrated unit in the steering column area of the vehicle as shown in Fig. 5, the control loop including the driver consists of the minimum number of elements. This structure contributes to minimize tuning work for each different vehicle type. Moreover, as there is no mechanical element such as an intermediate shaft that might adversely affect control system between the steering angle control unit and reactive torque compensation unit, it is possible to prevent such problems as resonance between these two units. Figures 6 and 7 show details of the steering angle control unit and reactive torque compensation unit, respectively. As described above, the optimal system has been established from the view of compensational steering control^{4),5)}.

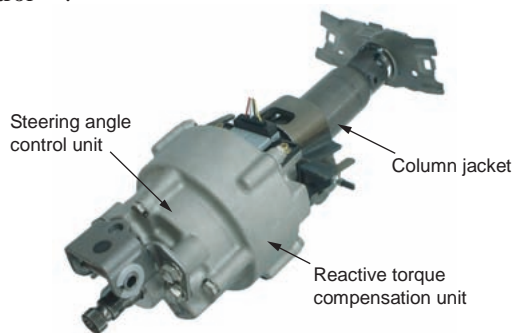

Fig. 4 Active-front-steering system

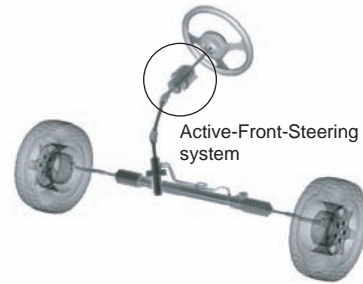

Fig. 5 Position of active-front-steering system

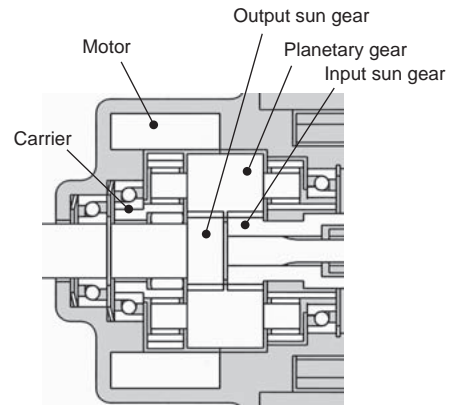

Fig. 6 Steering angle control unit

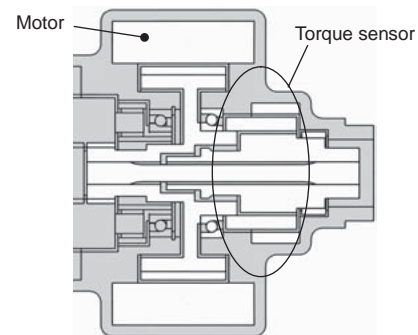

Fig. 7 Reactive torque compensation unit

3. Steering Angle Control Unit

The steering angle control unit consists of a differential planetary gear unit and a motor that drives this unit (Fig. 6). In order to achieve the target of high responsiveness and quietness required for steering angle control, we have taken the following measures:

- ① In order to eliminate vibration noise caused by the torque-transmission gears and achieve high responsiveness through low inertia, a specialized motor was manufactured.
- ② By using the profile shifted sun gears and adjusting the distance between the sun and planetary gears, two sun gears having different numbers of teeth were engaged with one planetary gear. This has enabled a simple structure with a small number of parts and also

cost reduction, weight reduction, and quietness because of improved accuracy.

- ③ By optimizing the reduction ratio of the differential planetary gear unit, improved quietness and high responsiveness from low inertia have been achieved.
- ④ When compensational steering is not being made, steering mechanism can connect directly by controlling the steering angle control unit not to rotate the planetary gear, and improved quietness and steering feeling is achieved.

4. Reactive Torque Compensation Unit

The reactive torque compensation unit is composed of a motor and a torque sensor and can provide independent reactive torque to the driver (Fig. 7). The output of the motor is designed for approximately 10 Nm, which is sufficient for reactive torque compensation. As in the case of the steering angle control unit, the reduction mechanism has been eliminated in order to achieve quietness and high responsiveness, and direct drive by a specialized motor was selected.

5. Control Logic

In this control logic, the value calculated from the steering angle, etc. input by the driver is regarded as the vehicle motion target value, and steering angle is controlled so that the target value corresponds to vehicle motion. For measurement of vehicle motion, a vehicle speed sensor, yaw rate sensor, and lateral acceleration sensor mounted in the vehicle are used. During this

steering angle control, reactive torque not intended by the driver occurs between the tires and road surface, making reactive torque compensation necessary. The target value of the reactive torque that should be returned to the driver is calculated from the steering angle, etc. input by the driver. Reactive torque compensation is made so that the target value corresponds to the value detected by the torque sensor. Figure 8 shows the control logic. In the case that, as a result of road surface conditions or external disturbances, vehicle motion differing from the target value calculated from the driver's steering wheel angle, etc. is detected, steering angle can be controlled to compensate vehicle motion and at the same time appropriate reactive torque provided to the driver.

6. Results of On-Vehicle Test

This system was mounted on an actual vehicle for evaluation. Evaluation was carried out by means of a split- μ braking test as shown in Fig. 9, a method widely used for evaluation of vehicle stabilization control. In a split- μ braking test, the driver applies the brakes suddenly and holds the steering wheel in the neutral position while driving the vehicle on a road having differing left and right friction coefficients. Test results are shown in Fig. 10. In the case of no steering angle control, the vehicle's direction and path deviated significantly from the target, but with steering angle control, tire angle was controlled automatically and the vehicle could be stopped with only slight deviation from the target in a straight direction. Also, the friction forces between the tires and road surface change during the test and a reaction force

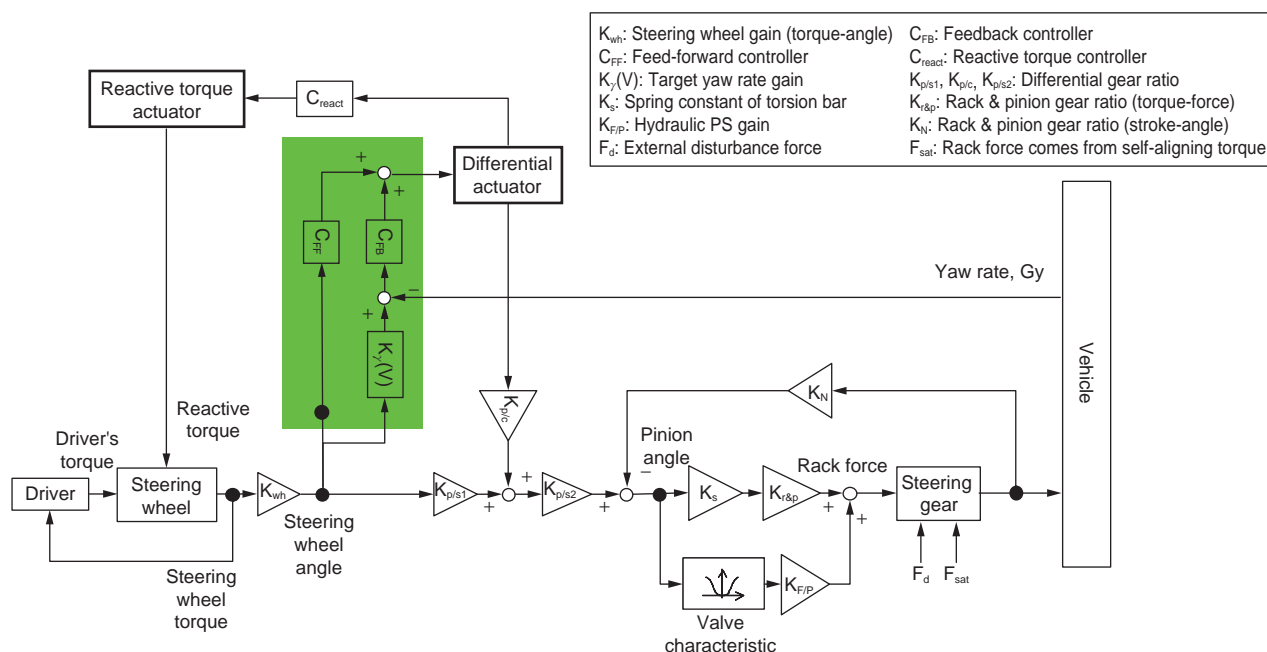

Fig. 8 Control logic

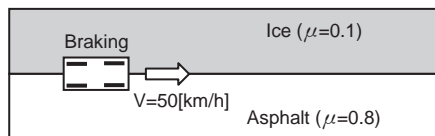

Fig. 9 Split- μ braking test

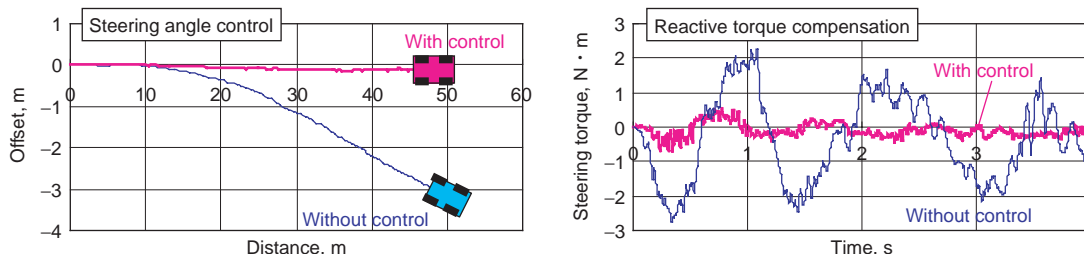

Fig. 10 Results of split- μ braking test

not intended by the driver occurs, but the reactive torque compensation control reduced the reactive torque nearly to a level not considered unpleasant by the driver. Thus it was verified that this system enables a vehicle to be stopped stably and contributes to improved safety during braking on split- μ roads, when normally a high level of driving skill is required to stop safely. Moreover, it was confirmed that application of this control improves safety in a wide variety of adverse situations, such as enabling straight driving in crosswinds by providing compensation to reduce driver load and by preventing spins during vehicle turns.

7. Conclusion

Using SBW, we previously had verified the effectiveness of improving vehicle stability by the steering system. SBW is an ideal system in regard to vehicle stability control because there is no mechanical connection between the steering wheel and tires and no interference with the driver's steering intention. However, as technology that can achieve both low cost and reliability has not yet been satisfied, SBW is still far from practical use.

In view of this situation, we developed a new system both satisfying the need for reliability and not interfering with the driver. The special feature of this system is that a single unit comprises two motors and a differential planetary gear mechanism and simultaneously compensates steering angle and reactive torque. Because tuning work per vehicle is minimized and the number of parts, the weight, and cost are reduced, this unit simultaneously achieves the required characteristics and performance. Moreover, the effectiveness of this system in improving vehicle stability has been verified by on-vehicle testing, and the possibility for this system to contribute to further improvement in vehicle safety has

been confirmed.

Finally, one of the authors won a JSME Young Engineers Award from The Japan Society of Mechanical Engineers in April 2008 for this research project. We are grateful to those who supported and guided us.

References

- 1) S. Nakano, T. Takamatsu, O. Nishihara, H. Kumamoto: Transaction of JSAE, vol. 31, no. 2 (2000) 53.
- 2) M. Segawa, S. Nakano, O. Nishihara, H. Kumamoto: JSAE Review, vol. 22, no. 4 (2001) 383.
- 3) S. Nakano, M. Segawa, K. Kato, H. Higashimura: Transaction of JSAE, vol. 32, no. 1 (2001) 95.
- 4) A. Kubo: Proceeding of MPT 2007 symposium <power transmission devise>, (2007) 1.
- 5) K. Yamanaka, S. Nakano: Proceeding of SAE World Congress, SP-2189, (2008) 67.



K. YAMANAKA*



A. ISHIHARA*

* Electronic Systems R&D Dept., Research & Development Center