

# Development of Assist Backup Control of the Electric Power Steering

N. URA

*Electric power steering (EPS) is a device which helps (assists) the driver's power which turns the steering wheel of the car. When EPS fails, the basic function which changes the direction of the car's movement is maintained. Furthermore, it is required that the function which assists the turning power of the steering wheel continues. In this report, I will introduce the control (Backup control) which assists steering wheel turning power even when EPS fails.*

**Key Words:** electric power steering, EPS, failure, Backup control, assist

## 1. Introduction

Power steering is a device which functions to change the ongoing direction of an automobile, equipped with motive power to assist the turning power of the steering wheel (SW) by making it easily maneuverable by the driver. Due to the demand for energy conservation, the motive power device is shifting from hydraulic pumps that continuously consume engine rotation energy, into an electric motor that consumes electrical energy only when necessary. This is known as Electric Power Steering (EPS, Fig. 1), which uses torque sensors to detect the driver's turning power (steering torque) of the SW and controls electric motor rotations with a motor control unit (MCU), to create an assisted power steering that is both light and comfortable. EPS is composed of many electronic components; if one of these parts fails, EPS assist stops, and the SW is unable to be steered easily and lightly. If EPS assist can be continued even when failure occurs, the driver can still steer using less power. In this report, I will introduce the development of Backup controls which allows the continuance of EPS assist even during failure.

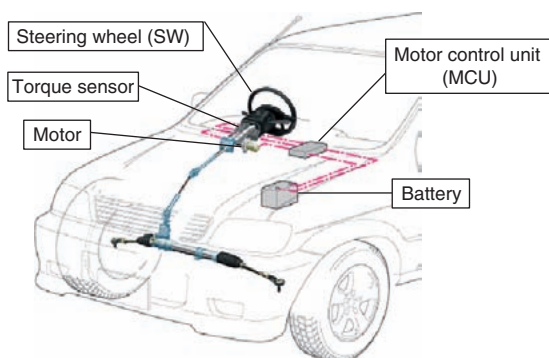

Fig. 1 Electric power steering (EPS)

## 2. EPS with High Reliance

When failure occurs, function is lost. Products influenced only slightly by failure can be said to have high reliance (Fig. 2). EPS failure status and degree of failure influence are shown in Table 1.

When EPS fails, it is assumed that inability to steer the wheel causes a large degree of influence. However, through countermeasures within design and manufacturing, EPS assist stoppage is the type of failure with the highest degree of influence. In order to minimize the degree of influence and eliminate the problem of EPS assist stoppage, EPS assist must be continued. If EPS assist continues even during failure, the degree of influence will be lessened, and the reliance of EPS will be greatly enhanced.

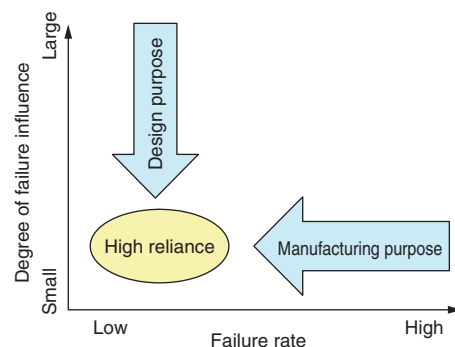

Fig. 2 Figure showing high reliance

**Table 1** Degree of influence of EPS failure

Degree of failure influence	Failure status	Details
<div style="display: flex; align-items: center; justify-content: center;"> <div style="writing-mode: vertical-rl; transform: rotate(180deg); font-weight: bold; margin-right: 10px;">Large</div> </div>	Steering inability	The driver is unable to control the direction of the automobile course.
	Difficulty steering	The driver struggles to control the direction of the automobile course.
	EPS assist stopped	EPS assist stops and the automobile reverts to manual steering.
	Changes in steering power	EPS assist decreases or assist characteristics change.
<div style="display: flex; align-items: center; justify-content: center;"> <div style="writing-mode: vertical-rl; transform: rotate(180deg); font-weight: bold; margin-right: 10px;">Small</div> </div>	Service deterioration	Unable to perform automatic parking or control straight course assistance (lane keeping assistance).
	Quality deterioration	Failure rate increases, or noise superimposes on the radio.

### 3. Backup Control

If EPS is able to continue the assist function even when assist stops due to a malfunction in an electrical component, the driver can continue steering lightly, just as before the failure occurred, and the degree of failure influence can be reduced. Electrical failures within EPS are usually the cause of a malfunction in a single electrical component, while all other components work normally. Backup control is using the normally functioning electrical components to continue assist. JTEKT Backup controls have a variety of control programs, and in this paper I will introduce the following three types of Backup controls.

#### 3.1 2-Phase Drive Backup Control

The electric circuit rotating the 3-phase brushless motor is comprised of a 3-phase inverter (U-phase, V-phase and W-phase) with 6 switches (MOS FET) (Fig. 3). It allows the electric current of each phase to flow depending on the motor rotating angle (electric angle) (Fig. 4), thereby rotating the 3-phase brushless motor. The electric current of each phase at this time is shown in the following formula.

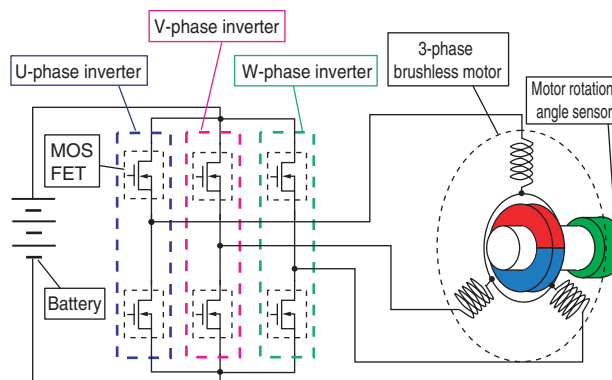

**Fig. 3** Circuit diagram of brushless motor

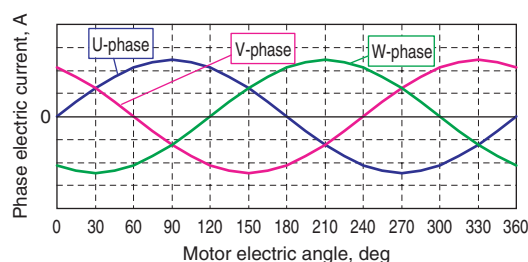

**Fig. 4** Relation between the motor electric angle and each electric current phase

$$\begin{pmatrix} I_u \\ I_v \\ I_w \end{pmatrix} = -\sqrt{\frac{2}{3}} \times I_q \times \begin{pmatrix} \sin \theta \\ \sin (\theta + 120) \\ \sin (\theta - 120) \end{pmatrix} \quad (1)$$

- $I_u$  : U-phase electric current [A]
- $I_v$  : V-phase electric current [A]
- $I_w$  : W-phase electric current [A]
- $I_q$  : Assist electric current [A]
- $\theta$  : Motor electric angle [deg]

If a single phase of the 3-phase inverter fails by being disconnected, the electric current for one phase stops flowing. For example, if the U-phase fails and the electric current cannot flow, electric current shown in the below formulas can be given to each phase to keep the motor rotating.

$$I_u = 0 \quad (2)$$

$$I_v = \frac{I_q}{\sqrt{2} \times \cos \theta} \quad (3)$$

$$I_w = -\frac{I_q}{\sqrt{2} \times \cos \theta} \quad (4)$$

By allowing motor electricity to flow with the aforementioned formulas, the motor can be rotated using the two normal phase inverters. However,  $\cos \theta$  is at zero when the motor electric angle is at 90 degrees or 270 degrees, and electric current of the V-phase and W-phase must flow indefinitely. For motor electric angles where

the motor permanent magnet field direction is parallel to the direction of the combined magnetic fields of the V-phase and W-phase, a problem may occur where the power rotating the motor (torque) is not generated. As a countermeasure, immediately before motor electric angles where there is no motor torque generated (90° and 270°), I increased motor rotation speed to pass over the angle. Motor electric current control (which controls the motor acceleration areas with the most motor electric current flow), along with the motor rotation direction, is presented in Fig. 5. 2-Phase Drive Backup Control has been completed by these control.

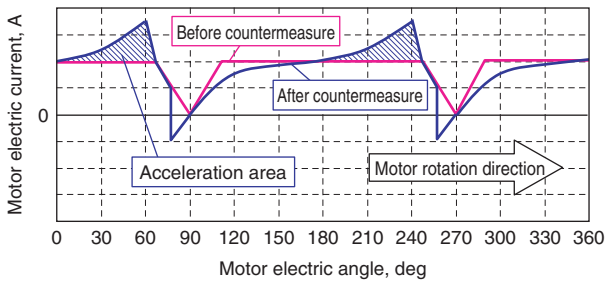

Fig. 5 Motor current before and after countermeasures

**3. 2 Motor Rotation Angle Sensor Backup Control**

As shown in Fig. 4, it is necessary to allow the flow of electric current corresponding to the motor electric angle to all three phases, in order to rotate the 3-phase brushless motor. However, if the motor rotation angle sensor fails, information for the motor electric angle cannot be obtained, and the amount of electric current flowing to the three phases cannot be known. To rotate the motor even when the motor rotation angle sensor fails, the motor electric angle must be calculated using a different method. Then, when the motor rotates, the induced voltage generated in U-phase, V-phase and W-phase can be utilized. More specifically, the motor electric angle is calculated by converting from the induced voltage by each phase corresponding to the motor electric angle, to the rectangular coordinates of  $\alpha$ - $\beta$  in the following formula.

$$\begin{pmatrix} e_\alpha \\ e_\beta \end{pmatrix} = \sqrt{\frac{2}{3}} \begin{pmatrix} 1 & -\frac{1}{2} & -\frac{1}{2} \\ 0 & \frac{\sqrt{3}}{2} & -\frac{\sqrt{3}}{2} \end{pmatrix} \begin{pmatrix} V_u \\ V_v \\ V_w \end{pmatrix} \tag{5}$$

- $e_\alpha$  :  $\alpha$  Induced voltage [V]
- $e_\beta$  :  $\beta$  Induced voltage [V]
- $V_u$  : U-phase induced voltage [V]
- $V_v$  : V-phase induced voltage [V]
- $V_w$  : W-phase induced voltage [V]

The induced voltage in the  $\alpha$ - $\beta$  axis is shown in the following formulas.

$$e_\alpha = -\omega \times K_e \times \sin\theta \tag{6}$$

$$e_\beta = \omega \times K_e \times \cos\theta \tag{7}$$

$\omega$  : Motor rotation angle speed [deg/s]

$K_e$  : Induced voltage constant

Therefore, the motor electric angle can be calculated using the following formula.

$$\theta = \tan^{-1} \left[ -\frac{e_\alpha}{e_\beta} \right] \tag{8}$$

As seen in formulas (6) and (7), induced voltage becomes smaller when the motor rotation angle speed is low, which creates a problem where the motor electric angle cannot be accurately calculated. To solve this, the motor electric angle is intentionally changed while holding the constant amount of motor electric current; the motor electric angle at the maximum motor torque will be the correct motor electric angle (Fig. 6). Likewise, the fluctuations in motor torque when measuring the motor electric angle cause fluctuations in the amount of EPS assist and in steering torque (Fig. 7). More specifically, when EPS assist amount decreases, the driver must operate the SW using more force, to compensate for the lost assist amount. Due to this, steering torque increases. On the contrary, when the assist amount increases, steering torque decreases. In other words, assist amount and steering torque fluctuate in conjunction with one another.

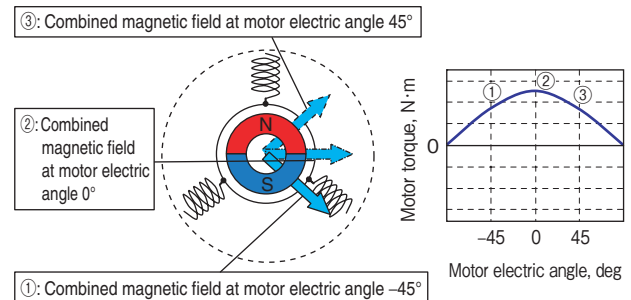

Fig. 6 Motor electric angle and motor torque

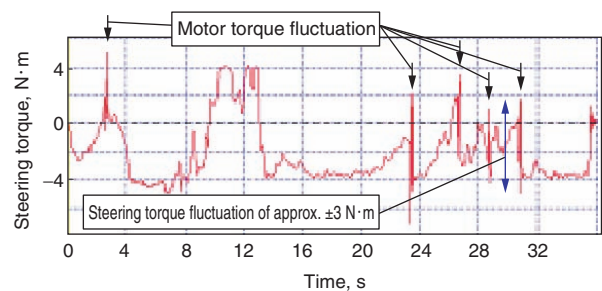

Fig. 7 Fluctuations of steering torque at motor rotation angle sensor backup control

When fluctuation in steering torque is made larger, the motor electric angle becomes easier to calculate, but automobile steering becomes difficult. Reversely, when the fluctuation is made smaller, steering is easier, but the motor electric angle error margin becomes greater. After examining steering torque within various driving and environment conditions, the results showed that approximately  $\pm 3 \text{ N}\cdot\text{m}$  is the optimum torque fluctuation for steering torque. From these results, I established a motor rotation angle sensor Backup control by setting steering torque fluctuation to approximately  $\pm 3 \text{ N}\cdot\text{m}$ .

### 3. 3 Torque Sensor Backup Control

EPS torque sensors are necessary for the MCU to determine assist amount, and are vital in detecting the steering torque of the driver. Therefore, JTEKT torque sensors have a redundant structure, with two IC units (an electrical component) in each group. The output signals of these two IC units are compared and the values confirmed to be the same, thereby determining the steering torque (Fig. 8).

If one of the two IC units fails, EPS assist is continued using the normal IC; this is torque sensor Backup control. However, specifying the normal IC is problematic. If the torque sensor fails, the two IC units will output different values, as shown in Fig. 9. The normal IC and the broken IC cannot be distinguished from one another using only this information.

The normal IC and the failed IC can be distinguished if there is other information, however. For example, if the driver is able to input the correct steering torque from the SW, a comparison of the input steering torque and the IC output signal will show which IC is normal and which has failed, as shown in Fig. 10.

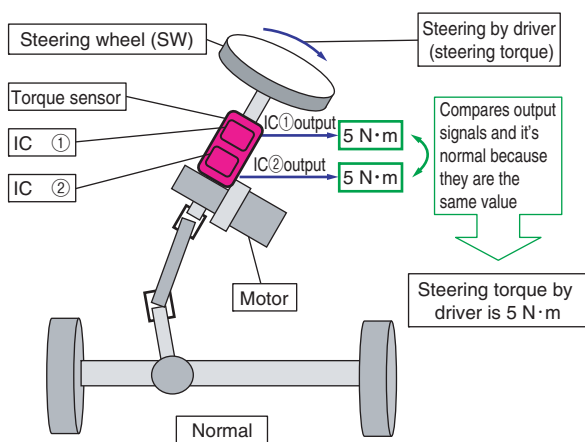

Fig. 8 Normal performance of the torque sensor

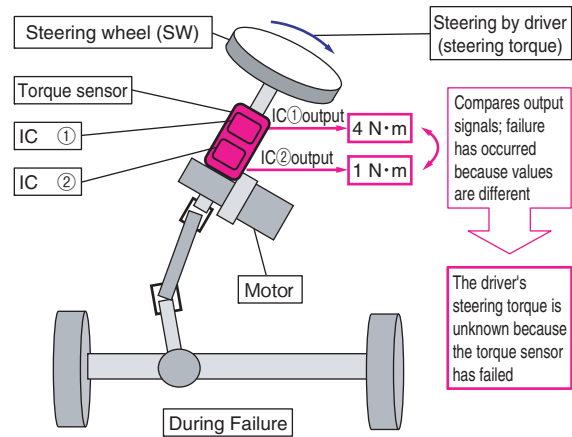

Fig. 9 Torque sensor failure

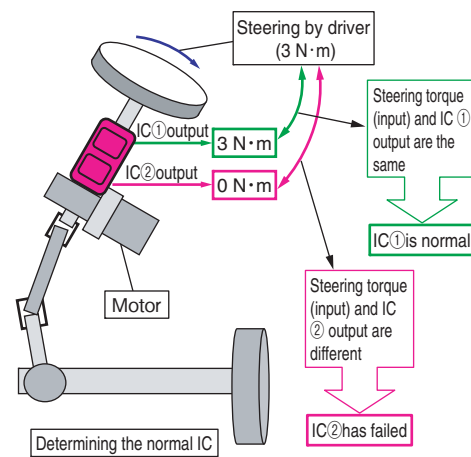

Fig. 10 IC failure criteria

However, the act of the driver inputting accurate steering torque from the SW is difficult. I shifted to the idea that steering torque could be inputted from the motor, which lies opposite the SW with the torque sensor in between. As shown in Fig. 11, comparing the steering torque input from the motor with the output signal of the IC unit will distinguish the normal IC from the failed IC. Steering torque input from an actual motor and an IC output signal are shown in Fig. 12. Discerning the normal IC requires decision criterion including not only the value of the steering torque, but also the lag time of steering torque output from the motor electric current command, as well as the steering torque direction. The steering torque signal from the normal IC can then be used to continue EPS assist, completing the Torque Sensor Backup Control.

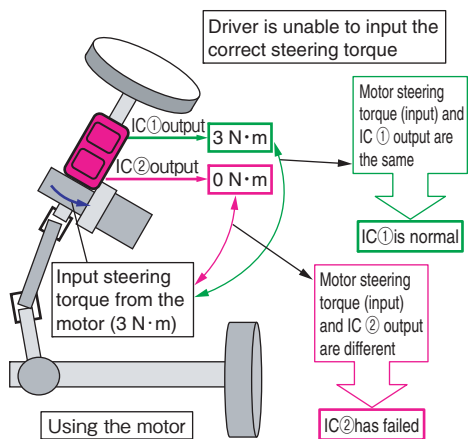

Fig. 11 Actual IC failure criteria

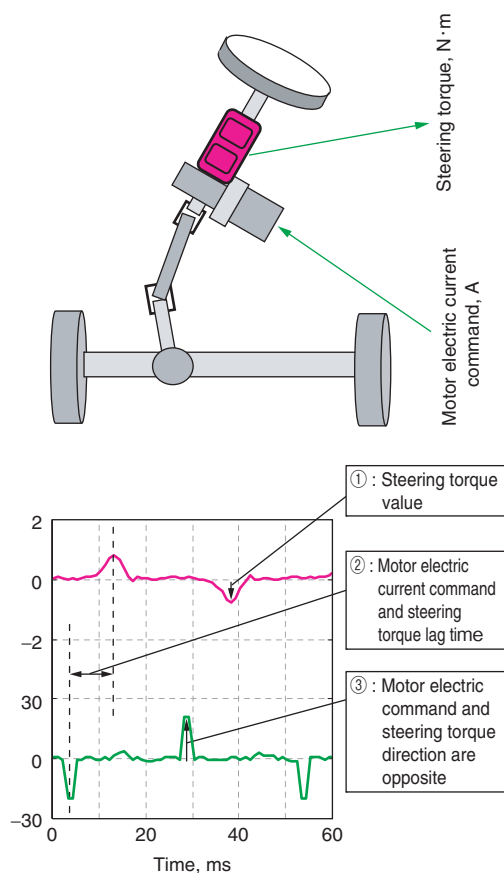

Fig. 12 Motor command value current and steering torque

### 4. Results

The three introduced Backup controls were measured on an actual automobile, the results of which are shown in Fig. 13. When the EPS assist stopped due to failure during a 20 km/h drive on a 20 m. radius curb, the steering torque increased from 2.1 N·m to 13.6 N·m. In other words, 6 times more load was put on the SW due to assist failure, and light steering became impossible. However, it was shown that steering with nearly the same

steering torque as before the failure is possible, no matter which Backup control for continuing assist is used. This means that the driver can operate the SW as lightly after the failure as before the failure.

In reality, the developed Backup controls are utilized only a little. This is because EPS failure (and therefore Backup control operation) is extremely rare. Due to this, the effects of Backup control are reviewed theoretically through the percentage of component failure and failure mode. A part of these reviews are shown in Table 2; Backup control operates to continue EPS assist for 39.8% of failures.

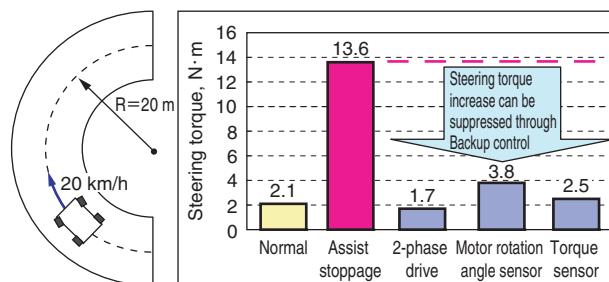

Fig. 13 Reduction of the steering torque by Backup control

Table 2 Desk review of the failure rate and failure mode of the electronic components

Component name	Failure rate	Failure mode	Failure ratio	Assist stoppage rate	Assist continuance rate
R10	2	Disconnected	90%		1.8
		Short circuit	10%	0.2	
D15	5	Disconnected	30%	1.5	
		Short circuit	10%	0.5	
		Drift small	30%		1.5
		Drift large	30%	1.5	

### 5. Conclusion

EPS installation rates have risen with the demand for energy conservation, and production volume is increasing. EPS has been requested higher reliance because the number of failures will increase if the failure rate remains the same.

My research discovered that by embedding Backup controls within EPS, the driver can operate the SW lightly even after a failure occurs. Allowing EPS assist to continue in this way reduces the degree of failure influence, raises the driver's peace of mind, and is effective in increasing the reliance of EPS.

With these Backup control technologies, the degree of failure influence is lowered and reliance is increased,

but the achievement of Backup controls corresponding to all types of failures is still incomplete. I would like to develop new types of Backup controls to be able to handle all types of failures.

### Reference

---

- 1) T. Nozawa, Y. Shintani, T. Tamaizumi, T. Hibi and H. Itamoto :  
JTEKT ENGINEERING JOURNAL, no.1008 (2010).



N. URA\*

\* *System Development Dept., Automotive Systems  
Business Headquarters*